

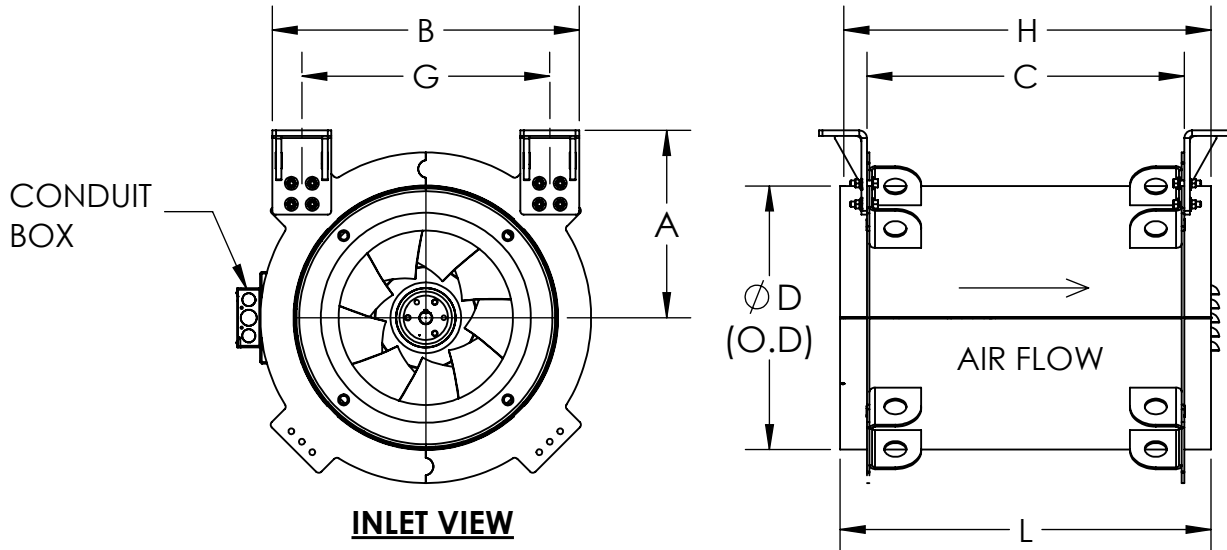

DATE: TAG:
 JOB:
 PROJECT:
 COMPANY:
 SALES PERSON:

MXI- ARRANGEMENT-4, LEVEL 1,
 HORIZONTAL CEILING HUNG



Standard Construction:

- 1.High Efficiency Welded Mixed Flow Wheel
- 2.Welded Guide Vanes
- 3.Extended Lube Lines
- 4.Motor Tunnel
- 5.Bolted Mounting Feet

Accessories:

- 1.AMCA B Spark Resistant Construction
- 2.AMCA C Spark Resistant Construction
- 3.Mounting Rails
- 4.Vibration Isolators
- 5.Piezo Ring
- 6.Disconnect Switch

- 7.Access Door- Hinged or Bolted
- 8.Copper Lube Lines
- 9.Inlet and/or Outlet Flange
- 10.Inlet and/or Outlet Guard
- 11.Companion Flange
- 12.Drain
- 13.Flexible Duct Connector
14. VFD

DIMENSIONAL DATA

Size	A	B	C	D	G	H	L	MAX MTR FRAME SIZE	LESS MOTOR WEIGHT (LBS.)
122	12 11/16	20 13/16	21 1/2	17 7/8	16 13/16	25 1/4	25 1/8	145T	139
135	14	22 1/8	24 3/16	19 3/4	18 1/8	28	27 13/16	145T	169
150	14 3/4	23 11/16	27 1/4	21 7/8	19 11/16	31 1/16	30 7/8	145T	197
165	15 5/16	24 3/4	30 3/8	23 3/8	20 3/4	34 1/8	33 15/16	184T	226
182	16 3/16	26 1/2	33 7/8	25 13/16	22 1/2	37 5/8	37 7/16	215T	291
200	17 1/16	28 5/16	37 9/16	28 3/8	24 5/16	41 5/16	41 3/16	215T	339
222	19 5/8	32 1/8	42 1/16	31 7/16	27 1/8	45 7/8	45 11/16	256T	476
245	20 7/8	34 7/16	46 13/16	34 11/16	29 7/16	52 1/16	50 7/16	256T	572
270	22 1/8	36 15/16	51 15/16	38 3/16	31 15/16	57 1/4	55 9/16	286T	716
300	24 3/4	40 5/8	58 1/8	42 7/16	35 5/8	63 7/16	61 3/4	286T	861
330	26 1/4	43 5/8	64 3/8	46 5/8	38 5/8	69 5/8	68	286T	1007
365	29	47 5/8	71 1/2	51 9/16	42 1/8	77 1/16	75 1/8	326T	1358
402	31 7/8	51 1/8	79 1/8	56 3/4	45 13/16	84 11/16	82 3/4	365T	1633
445	34 5/16	56 5/16	88	62 13/16	50 13/16	93 1/2	91 5/8	365T	1909
490	38 1/2	63 3/4	97 1/4	69 1/8	56 1/4	104 1/4	100 7/8	365T	2565
542	41 7/16	69 5/8	107 15/16	76 7/16	62 1/8	115	111 9/16	405T	2984
600	46 1/2	76 3/8	119 7/8	84 9/16	67 3/8	126 15/16	123 1/2	444T	3606

ALL DIMENSIONS ARE IN INCHES

REVISION:

FORM:

REPLACES: